

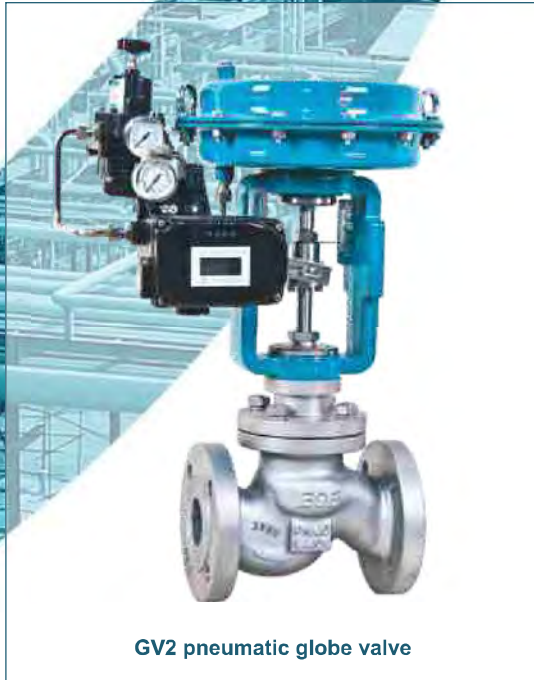

ecoflo[®]-GV
Pneumatic Globe Valves

ecoflo-GV

PNEUMATIC CONTROL VALVES
PN16 / PN25 / PN40 / ANSI 150 / ANSI 300



GV2 pneumatic globe valve

ecoflo-GV series pneumatic control valves are designed for the control of liquids, gases, and steam from size DN15 (1/2") up to DN300 (12"). Larger sizes are optionally available.

Globe valves are a traditional solution for most of the industrial applications thanks to its long-term seat tightness, robust construction, and a wide variety of construction materials. They are preferred mostly for regulation duty due to their proper flow characteristics for purpose.

Typical control applications include regulation of temperature, pressure, flowrate and level, besides many more applications found around wherever industrial automations is involved.

Produced in Turkey under ISO 9001:2008 Quality Assurance System, *ecoflo-GV* series pneumatic control valves are used in almost all process industries like chemical and petrochemical plants, refineries, power plants, metallurgical mills, paper mills, food and pharmaceutical industries, water treatment, as well as in machinery automation like textile, food and packaging.

General Features

- 2-way or 3-way design
- Wide selection of construction materials
- EN pressure classes of PN15, PN25 and PN40 or ANSI pressure classes of ANSI 150 and ANSI 300. Additional models are available for higher pressure classes.
- Flanged, threaded or welded connections
- Leakage Class IV, V or VI
- Materials and test certificates to international standards
- Process temperature range between -30....+400°C. Consult for different ranges
- Ambient temperature range between -30....+60°C
- Diaphragm type pneumatic actuators from 80 cm² up to 3000 cm², and piston type pneumatic actuators from diameter 50 mm up to 125 mm
- Standard design is normally closed, air to open or normally open, air to close
- Choice of analog or digital positioners
- IP66 to IP68 protection, ex-proof models
- Trouble-free operation by integration of industrial air filter-regulators
- Optional manual override
- Optional position switches, air solenoids, lock-up valves, boosters, and other auxiliary accessories

WORKING CONDITIONS TO EN 22401				
Maximum Working Temperature °C	Maximum Body Working Pressure (bar)			
	PN16 Material Code		PN25 Material Code	PN40 Material Code
	GG-25	GGG-40/50	GGG-40/50	GS-C25 / WCB, 1.4571
-10 +120	16	16	25	40
200	13	13	20	35
250	11	12	18	32
300	10	11	16	28
350	-	10	15	24
400	-	-	-	21

Maximum working temperature for each pressure class and the relevant maximum working pressure values are shown in "Working Conditions" tables according to EN and ASME standards. Cast iron (GG-25) and ductile iron (GGG-40 or GGG-50) valves are suitable for mostly used industrial fluids like water, condensed water, steam and air.

Cast steel (GS-C25 or WCB) bodied valves, however, are more appropriate for heavier working conditions where pressure shocks, high vibration or sudden temperature changes may occur.

Stainless steel (AISI304, 316, 316L, 316Ti) valves and thermoplastic (PP, PVC, and alike) valves as well as fluoropolymer (PFA, PTFE) valves are preferred for aggressive or corrosive chemical fluids or for corrosive environment. Special exotic alloys are also available for more specific applications. One should consider the strongest possible working conditions while selecting a valve.

Thrust forces required to close or open a globe valve are dependant on valve size and pressure drop across valve, in other words, pressure difference between inlet and outlet of the valve. Maximum pressure difference values achieved with different actuator models are given in "Technical Data" table.



WORKING CONDITIONS TO ANSI B16.34				
Maximum Working Temperature °C	Maximum Body Working Pressure (bar)			
	Class 150 Material Code		Class 300 Material Code	
	GS-C25 / WCB	CF8M	GS-C25 / WCB	CF8M
-29 +38	19,6	19,0	51,1	49,6
100	17,7	16,2	46,4	42,2
200	14,0	13,7	43,8	35,7
300	10,2	10,2	38,7	31,6
400	6,5	6,5	34,5	29,1
425	5,6	5,6	28,8	28,7



GV2 pneumatic globe valve with analog positioner



GV2 pneumatic globe valve with digital positioner

ORDERING CODE

Model	Design	Body Material	Size	Connections	Actuator	Temperature	Control Mode	Options
<i>ecoflo</i>	GV2 : 2-Way	0 : AISI316	15	0 : Welded	50 (Piston)	C : -196 ... 100 °C	0 : On-Off	0 : None
	GV3 : 3-Way	01 : Solid PTFE with SS enclosure	20	1 : Threaded	80 (Piston)	1 : -50 ... 220 °C	1 : Linear Manuel Valve	NO : Normally Open
		2 : Bronze / Brass	25	F0 : Flanged PN10	125 (Piston)	2 : 0 ... 400 °C	PP1 : Linear, P/P Positioner	DA : Double Action
		3 : GG-25 Cast Iron	32	F1 : Flanged PN16	240 (Diaphragm)	3 : 0 ... 500 °C	PP2 : Equal %, P/P Positioner	LS1 : 1 Limit Switch
		4 : GGG40/50 Ductile Iron	40	F2 : Flanged PN25	350 (Diaphragm)	4 : 0 ... 550 °C	IP1 : Linear, I/P Positioner	LS2 : 2 Limit Switches
		5 : GS-C25 / WCB Cast Steel	50	F3 : Flanged PN40	600 (Diaphragm)	ST : Special Range	IP2 : Equal%, I/P Positioner	M : Hand Wheel
		51 : Steel, PTFE Coated	65	F4 : Flanged ANSI 150	700 (Diaphragm)			SL : Stroke Limitation
		6 : AISI 304	80	F5 : Flanged ANSI 300	900 (Diaphragm)			SK : Reduced Kvs / Cv
		7 : Thermoplastics	100	SF : Special	1300 (Diaphragm)			SV32 : 3/2 Way Air Solenoid
		X : Other	125	X : Other	3000 (Diaphragm)			SV52 : 5/2 Way Air Solenoid
			150		H : None (Manual)			FR : Air Filter - Regulator
			200		X : Other			PB : Pressure Balanced Trim
			250					VB : Volume Booster
			300					LUV : Lock-up Valve
								X : Other

Sample ordering code : *ecoflo*-GV2-3-15-F1-240-1-IP1-FR

(Pneumatic 2-way globe valve, cast iron body, DN15 PN16 flanged, with PA240 pneumatic actuator, temperature between -50-200°C, linear characteristics with I/P positioner, with air filter regulator)

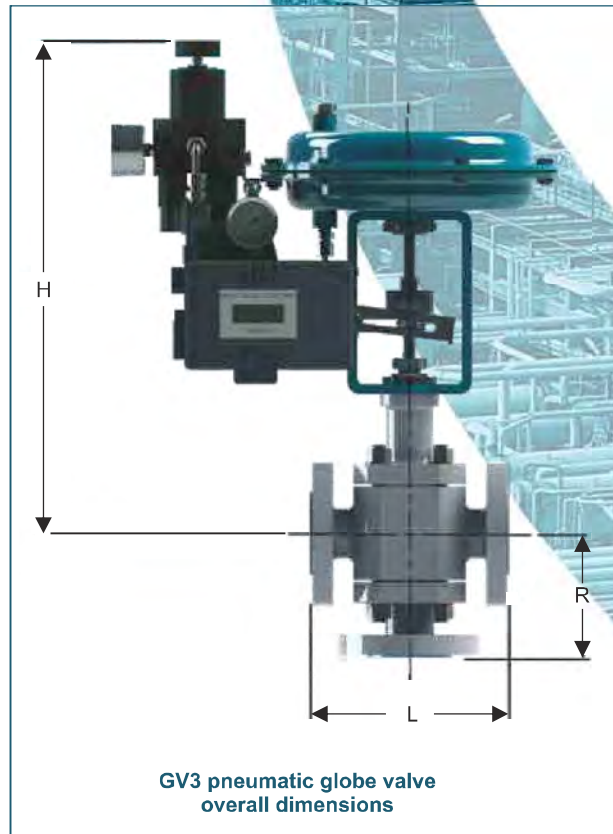
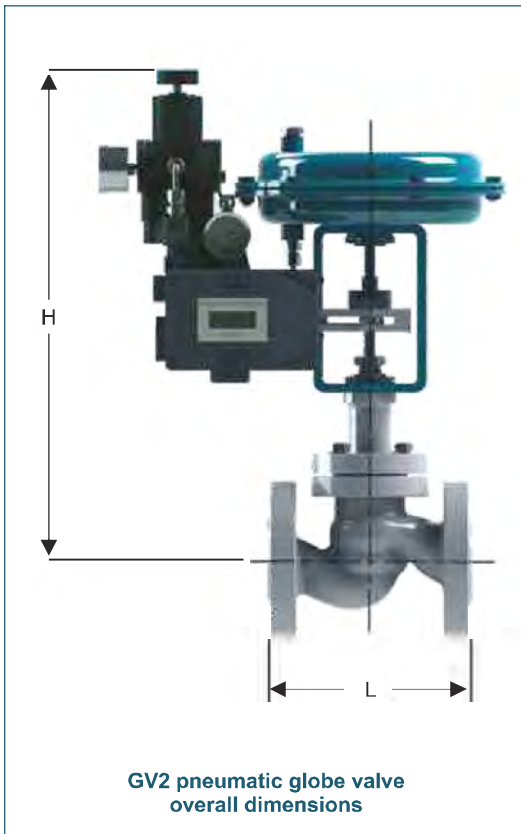

SHUT-OFF PRESSURE (bar) vs. VALVE SIZE / ACTUATOR COMBINATION

Valve Size		Kvs ²	Cv ²	Stroke ¹	Actuator Model										
					PA80	PA240			PA350			PA600 PA700	PA900	PA1300	PA3000
DN	Inch			mm	SPRING RANGE (bar)										
					0.2-1.0	0.2-1.0	0.2-2.0	0.3-3.0	0.2-1.0	0.2-2.0	0.3-3.0	0.8-2.4	0.8-2.4	0.8-2.4	0.6-1.7
15	1/2"	4	4,6	10	6,3	40	40	40	-	-	-	-	-	-	-
20	3/4"	6,4	7,4	12	3,5	24	40	40	-	-	-	-	-	-	-
25	1"	11	13	14	2,2	12	25	38	37	40	-	-	-	-	-
32	1 1/4"	16	19	16	-	5,8	11	17	20	31	40	-	-	-	-
40	1 1/2"	26	30	18	-	2,5	5,0	7,6	11	18	27	40	-	-	-
50	2"	45	52	20	-	-	1,7	2,5	6,2	10	15	33	40	-	-
65	2 1/2"	52	60	25	-	-	-	-	3,6	5,9	8,8	19	35	40	-
80	3"	92	107	25	-	-	-	-	1,4	2,4	3,6	11	21	32	-
100	4"	154	179	30	-	-	-	-	-	-	-	6,0	12	19	-
125	5"	237	275	35	-	-	-	-	-	-	-	3,1	7,3	11	19
150	6"	338	392	40	-	-	-	-	-	-	-	1,9	4,6	7,2	12
200	8"	560	650	50	-	-	-	-	-	-	-	-	2,0	3,3	6,1
250	10"	870	1010	60	-	-	-	-	-	-	-	-	-	1,6	2,9
300	12"	1260	1462	70	-	-	-	-	-	-	-	-	-	-	1,8

Note : Above table is valid for single-seated, full orifice, top-guided, flow under seat and normally closed valves.

Pressure values in the table may increase for reduced orifice sizes.

1 : Standard design values. Different values may apply.

2 : Values may decrease depending on valve sizing.

GV SERIES PNEUMATIC CONTROL VALVES - TECHNICAL DATA

Size		Actuator	Installation Length				Height			On-Off		Regulation		Weight* (kg)		
DN	Inch	(cm ²)	L (mm) ¹	L (mm) ²	L (mm) ³	R (mm)	H (mm)	H (mm) ⁴	H (mm) ⁵	Kvs	Cv	Kvs	Cv	A ⁴	A1 ⁵	A2 ⁶
15	1/2"	240	130	108	152	90	490	590	-	6	7	4	4,6	14	16	-
20	3/4"	240	150	118	178	95	490	590	-	10	11,6	6,4	7,4	14	16	-
25	1"	240	160	127	204	100	500	600	-	14	16	11	13	16	18	-
32	1 1/4"	240	180	-	-	105	500	600	-	19	22	16	19	17	19	-
32	1 1/4"	350	180	-	-	105	530	785	835	19	22	16	19	24	27	33
40	1 1/2"	240	200	165	229	115	507	607	-	32	37	26	30	20	22	-
40	1 1/2"	350	200	165	229	115	535	790	845	32	37	26	30	27	30	36
40	1 1/2"	600	200	165	229	115	580	915	970	32	37	26	30	42	46	57
50	2"	240	230	203	267	125	510	610	-	50	58	45	52	22	24	-
50	2"	350	230	203	267	125	540	795	845	50	58	45	52	29	33	39
50	2"	600	230	203	267	125	858	980	975	50	58	45	52	44	48	60
65	2 1/2"	350	290	216	292	145	565	820	870	75	85	52	60	35	39	44
65	2 1/2"	600	290	216	292	145	600	940	990	75	85	52	60	49	54	71
65	2 1/2"	900	290	216	292	145	715	1140	1140	75	85	52	60	96	123	154
65	2 1/2"	600	290	216	292	145	600	940	990	75	85	52	60	53	57	68
80	3"	350	310	241	318	155	580	835	885	120	140	92	107	38	41	47
80	3"	600	310	241	318	155	615	950	1000	120	140	92	107	53	57	68
80	3"	900	310	241	318	155	730	1155	1155	120	140	92	107	99	126	158
80	3"	600	310	241	318	155	615	950	1000	120	140	92	107	57	61	72
100	4"	350	350	292	356	175	590	845	900	185	215	154	179	51	55	61
100	4"	600	350	292	356	175	625	960	1015	185	215	154	179	66	70	82
100	4"	900	350	292	356	175	745	1170	1170	185	215	154	179	112	140	178
100	4"	600	350	292	356	175	625	960	1015	185	215	154	179	73	78	89
125	5"	600	400	355	400	180	660	995	1045	285	335	237	275	85	89	101
125	5"	900	400	355	400	180	775	1200	1200	285	335	237	275	131	159	190
125	5"	-	400	355	400	180	785	-	1295	285	335	237	275	306	-	358
125	5"	600	400	355	400	180	660	995	1045	285	335	237	275	96	100	111
150	6"	900	480	407	445	200	795	1220	1220	400	470	338	392	152	180	211
150	6"	-	480	407	445	200	800	-	1315	400	470	338	392	327	-	380
150	6"	900	480	407	445	200	675	1010	1065	400	470	338	392	167	194	226
200	8"	900	600	495	559	-	815	1240	1240	720	840	560	650	189	216	248
200	8"	-	600	495	559	-	825	-	1335	720	840	560	650	363	-	416
200	8"	900	600	495	559	-	700	1035	1090	720	840	560	650	211	238	270
250	10"	-	730	600	622	-	940	-	1455	1115	1200	870	1010	514	-	567
250	10"	-	730	600	622	-	815	1150	1205	1115	1200	870	1010	567	-	620
300	12"	-	850	622	711	-	915	1250	1305	1890	1620	1260	1462	655	-	708

(1) : PN16 / 25 / 40 body standards

(2) : ANSI 150 body standard

(3) : ANSI 300 body standard

(4) : Standard weight (without handwheel)

(5) : With top – mounted handwheel

(6) : With side – mounted handwheel

Note : Weights may differ depending on design



MULTI-HOLE PLUG WITH EQUAL PERCENTAGE FLOW CHARACTERISTICS



MULTI-HOLE PLUG WITH LINEAR FLOW CHARACTERISTICS



SLOTTED PLUG WITH LINEAR FLOW CHARACTERISTICS



CONTOURED PLUG WITH LINEAR OR EQUAL PERCENTAGE FLOW CHARACTERISTICS



ON-OFF PLUG

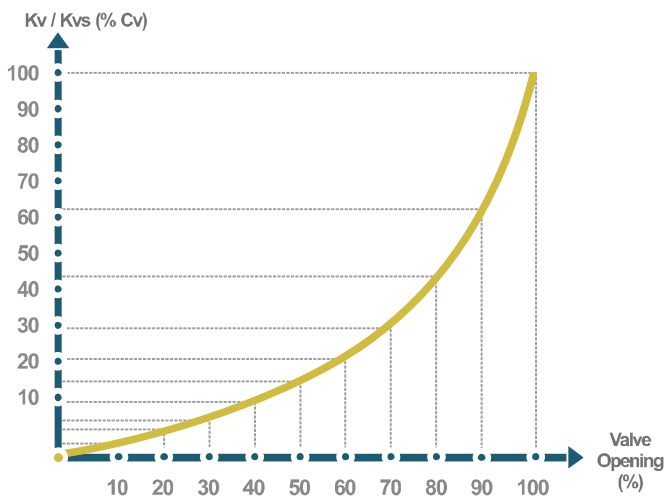

EQUAL PERCENTAGE FLOW CHARACTERISTICS

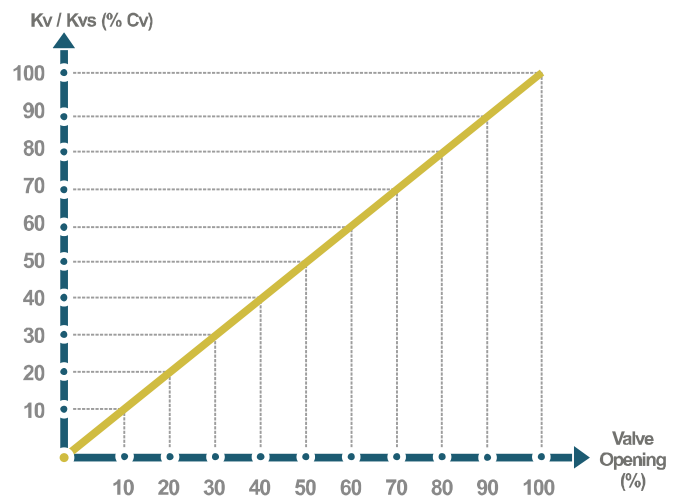

LINEAR FLOW CHARACTERISTICS

Kvs TABLE FOR LINEAR CHARACTERISTICS

Valve Size		Stroke ¹	Seat Diameter ¹	Max. Kvs	Max. Cv	Kv vs. % Valve Opening									
DN	inch	mm	mm			10%	20%	30%	40%	50%	60%	70%	80%	90%	100%
15	1/2"	10	15	4	4,6	0,4	0,8	1,2	1,6	2,0	2,4	2,8	3,2	3,6	4,0
20	3/4"	12	20	6,4	7,4	0,6	1,3	1,9	2,6	3,2	3,8	4,5	5,1	5,8	6,4
25	1"	14	25	11	13	1,1	2,2	3,3	4,4	5,5	6,6	7,7	8,8	9,9	11,0
32	1 1/4"	16	32	16	19	1,6	3,2	4,8	6,4	8,0	9,6	11,2	12,8	14,4	16,0
40	1 1/2"	18	40	26	30	2,6	5,2	7,8	10,4	13,0	15,6	18,2	20,8	23,4	26,0
50	2"	20	50	45	52	4,5	9,0	13,5	18,0	22,5	27,0	31,5	36,0	40,5	45,0
65	2 1/2"	25	65	52	60	5,2	10,4	15,6	20,8	26,0	31,2	36,4	41,6	46,8	52,0
80	3"	28	80	92	107	9,2	18,4	27,6	36,8	46,0	55,2	64,4	73,6	82,8	92,0
100	4"	30	100	154	179	15,4	30,8	46,2	61,6	77,0	92,4	107,8	123,2	138,6	154,0
125	5"	35	125	237	275	23,7	47,4	71,1	94,8	118,5	142,2	165,9	189,6	213,3	237,0
150	6"	40	150	338	392	33,8	67,6	101,4	135,2	169,0	202,8	236,6	270,4	304,2	338,0
200	8"	50	200	560	650	56,0	112,0	168,0	224,0	280,0	336,0	392,0	448,0	504,0	560,0
250	10"	60	250	870	1010	87,0	174,0	261,0	348,0	435,0	522,0	609,0	696,0	783,0	870,0
300	12"	70	300	1260	1462	126,0	252,0	378,0	504,0	630,0	756,0	882,0	1008,0	1134,0	1260,0

1 : Standard design values. Different values may apply.

Note : Above table is valid for single-seated, full orifice, top-guided, flow under seat and normally closed valves.

Values in the table may decrease for reduced orifices.

Kvs TABLE FOR EQUAL PERCENTAGE CHARACTERISTICS

Valve Size		Stroke ¹	Seat Diameter ¹	Max. Kvs	Max. Cv	Kv vs. % Valve Opening									
DN	inch	mm	mm			10%	20%	30%	40%	50%	60%	70%	80%	90%	100%
15	1/2"	10	15	4	4,6	0,05	0,12	0,21	0,35	0,5	0,8	1,2	1,7	2,5	4,0
20	3/4"	12	20	6,4	7,4	0,09	0,20	0,34	0,6	0,8	1,3	1,9	2,7	4,0	6,4
25	1"	14	25	11	13	0,15	0,34	0,6	1,0	1,4	2,2	3,2	4,7	6,9	11,0
32	1 1/4"	16	32	16	19	0,22	0,5	0,9	1,4	2,1	3,2	4,7	6,8	10,0	16,0
40	1 1/2"	18	40	26	30	0,35	0,8	1,4	2,3	3,4	5,2	7,6	11,0	16,2	26,0
50	2"	20	50	45	52	0,6	1,4	2,4	4,0	5,9	9,0	13,1	19,1	28,0	45,0
65	2 1/2"	25	65	52	60	0,7	1,6	2,8	4,6	6,8	10,4	15,2	22,1	32,4	52,0
80	3"	28	80	92	107	1,3	2,9	4,9	8,1	12,1	18,4	26,8	39,0	57,3	92,0
100	4"	30	100	154	179	2,1	4,8	8,2	13,5	20,2	30,8	44,9	65,3	95,9	154,0
125	5"	35	125	237	275	3,2	7,3	12,6	20,8	31,1	47,4	69,1	100,6	147,7	237,0
150	6"	40	150	338	392	4,6	10,5	18,0	29,7	44,4	67,6	98,6	143,4	210,6	338,0
200	8"	50	200	560	650	7,6	17,4	29,8	49,2	73,5	112,0	163,3	237,6	348,9	560,0
250	10"	60	250	870	1010	11,8	27,0	46,4	76,5	114,2	174,0	253,7	369,1	542,0	870,0
300	12"	70	300	1260	1462	17,1	39,1	67,2	110,8	165,4	252,0	367,4	534,6	785,0	1260,0

1 : Standard design values. Different values may apply.

Note : Above table is valid for single-seated, full orifice, top-guided, flow under seat and normally closed valves.

Values in the table may decrease for reduced orifices.

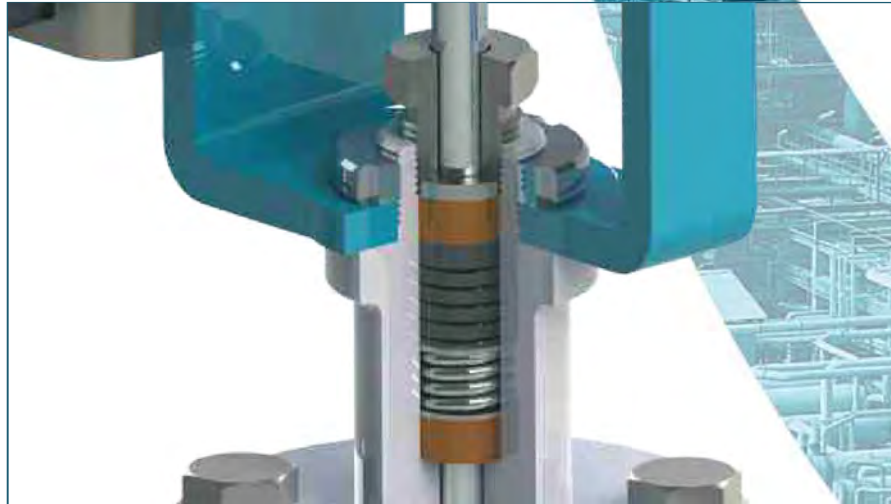

V-RINGS WITH SPRING LOAD

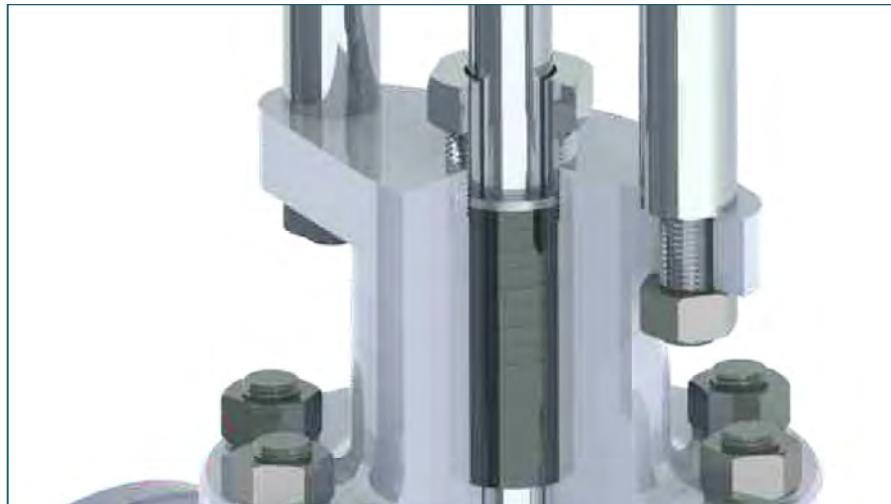

S.S. REINFORCED GRAPHITE

PACKING SELECTION GUIDE		
Packing Material	Max. Temperature	Pressure
	(°C)	(bar)
Pure PTFE	220	-
PTFE, carbon filled	220	-
Graphite, SS Reinforced	550	<63
Graphite, Spiral Wound	550	>63

2-way Pneumatic Globe Valves (Standard Design)

GV2 series pneumatic control valves with standard design are used for the control of liquids, gases and steam.

Examples to typical control applications are regulation of temperature, pressure, flowrate and level, whereas other physical and chemical parameters are also likely to be controlled by means of a control valve.

In most applications, GV2 series control valves are used as a regulation valve with integration of an electro-pneumatic positioner, either conventional analog type or advanced digital type with full programmability functions as well as digital interfaces for remote programming, data acquisition and supervision.



**GV2 pneumatic globe valve
With top-mounted hand wheel**

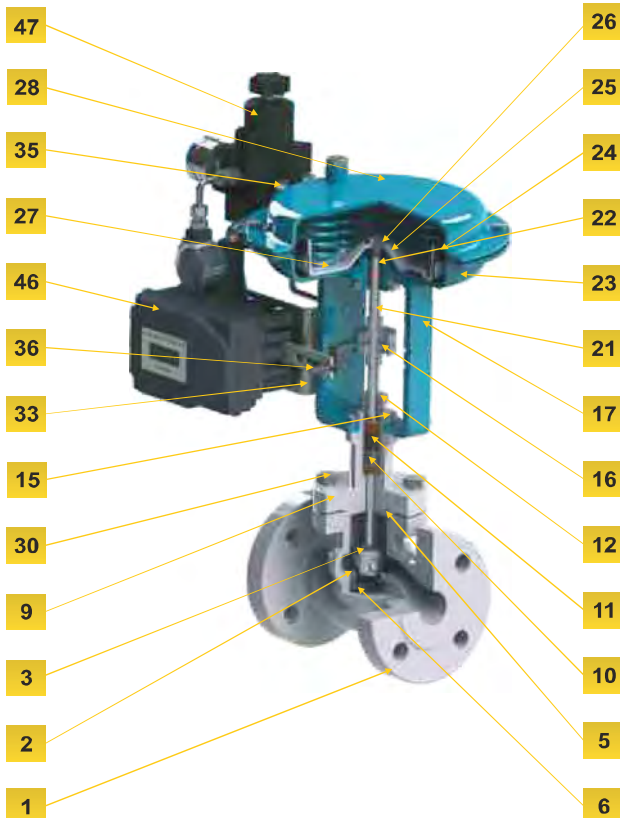

TYPICAL SECTIONAL DRAWING

Part No	Part Name	Material
1	Body	GG-25. GGG40/50. GS-C25. WCB. AISI 304 / 316
2	Seat	AISI316
3	Trim	AISI316
5	Body Seal	GRAPHITE
6	Seat Seal	GRAPHITE
9	Bonnet	GG-25. GGG40/50. GS-C25. WCB. AISI 304 / 316
10	Packing Spring	AISI316
11	Packing	PTFE, GRAPHITE
12	Packing Nut	S.S.
15	Yoke Nut	S.S.
16	Coupling	S.S.
17	Yoke	GGG40/ST37
21	Actuator Stem	S.S.
22	Pneumatic Seals	NBR
23	Actuator Lower Case	C.STEEL
24	Diaphragm	NBR REINFORCED
25	Piston	C.STEEL
26	Piston Nut	S.S.
27	Actuator Spring	C.STEEL
28	Actuator Upper Case	C.STEEL
30	Bolt	8.8
33	Positioner Bracket	S.S.
35	Air Filter Bracket	S.S.
36	Pin	S.S.
46	Positioner	-
47	Filter Regulator	-

Note :Materials of construction may change depending on application

3-way Pneumatic Globe Valves (Standard Design)

GV3 series 3-way pneumatic control valves are used as diverting or mixing valves.

Used mostly with thermal liquid (cooling or heating water, thermal oil, etc.), 3-way valves find their major applications as mixing or diverting valves at the inlets and outlets of pumps and heat exchangers. Another typical application is the mixing for cold and hot media to achieve a preset intermediate temperature value.

In most applications, GV3 series control valves are used as a regulation valve with integration of a electro-pneumatic positioned, either conventional analog type or advanced digital type with full programmability functions as well as digital interfaces for remote programming data acquisition and supervision.



GV3 3-way pneumatic globe valve

TYPICAL SECTIONAL DRAWING		
Part No	Part Name	Material
1	Body	GG-25. GGG40/50. GS-C25. WCB. AISI304 / 316
2	Seat	AISI316
3	Trim	AISI316
5	Body Seal	GRAPHITE
6	Seat Seal	GRAPHITE
9	Bonnet	GG-25. GGG40/50. GS-C25. WCB. AISI304 / 316
10	Packing Spring	AISI316
11	Packing	PTFE, GRAPHITE
12	Packing Nut	S.S.
15	Yoke Nut	S.S.
16	Coupling	S.S.
17	Yoke	GGG40/ST37
21	Actuator Stem	S.S.
22	Pneumatic Seals	NBR
23	Actuator Lower Case	C.STEEL
24	Diaphragm	NBR REINFORCED
25	Piston	C.STEEL
26	Piston Nut	S.S.
27	Actuator Spring	SPRING STEEL
28	Actuator Upper Case	C.STEEL
29	Stud	AISI4140
31	Nut	8.8
32	Flange	AISI4140
33	Positioner Bracket	S.S.
35	Air Filter Bracket	S.S.
36	Pin	S.S.
46	Positioner	-
47	Filter Regulator	-

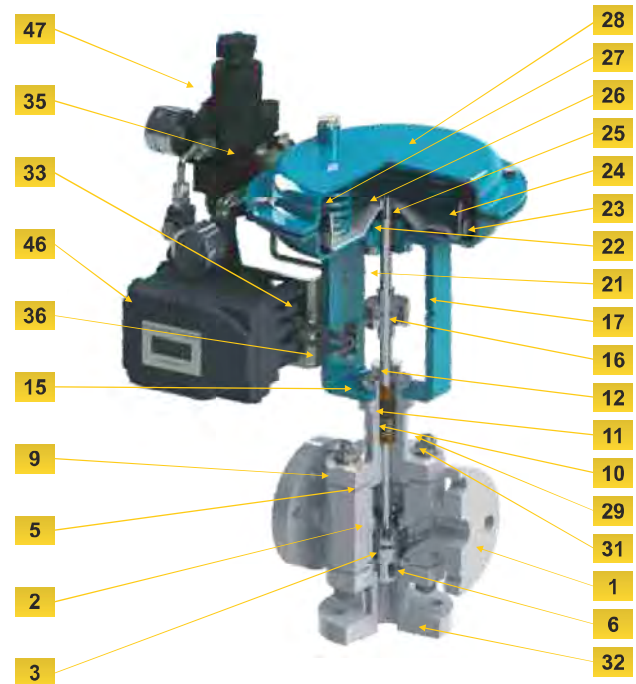

Note :Materials of construction may change depending on application

Micro-Flow Control Valves

GV2 series micro-flow control valves are used for the control of liquids, gases and steam, designed to have a process connection size of DN 15 (1/2"). These valves target the applications requiring Kvs values between 0.1 – 4.0 (Cv values between 0.1 – 4.6), in other words, control of very low flowrates. Main areas of use are R&D studies and system prototype tests for industrial enterprises, universities and research institutes, whereas the valves can be used directly in the process as well, thanks to its industrial design.

GV2 series micro-flow control valves are used as a regulation valve with integration of a electro-pneumatic positioner, either conventional analog type or advanced digital type with full programmability functions as well as digital interfaces for remote programming, data acquisition and supervision.

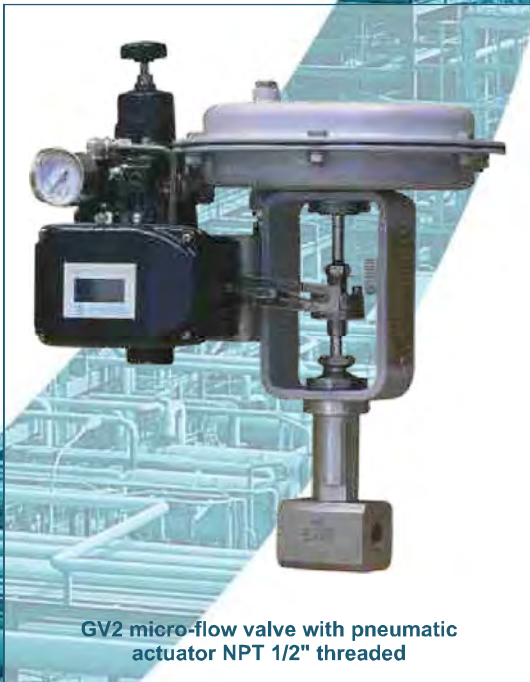

GV2 micro-flow valve with pneumatic actuator NPT 1/2" threaded

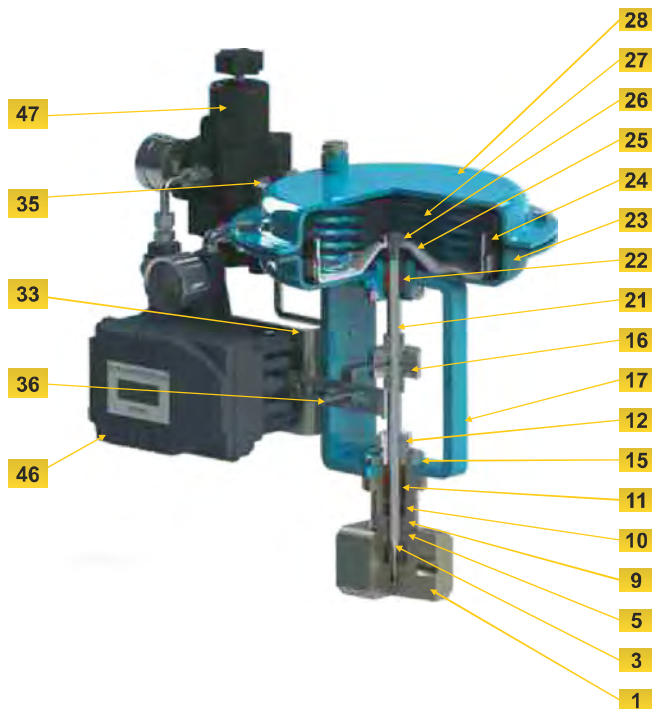

TYPICAL SECTIONAL DRAWING

Part No	Part Name	Material
1	Body	AISI 304 / 316
3	Trim	AISI316
5	Body Seal	GRAPHITE
9	Bonnet	AISI304 / 316
10	Packing Spring	AISI316
11	Packing	PTFE, GRAPHITE
12	Packing Nut	S.S.
15	Yoke Nut	S.S.
16	Coupling	S.S.
17	Yoke	ST37
21	Actuator Stem	S.S.
22	Pneumatic Seals	NBR
23	Actuator Lower Case	C.STEEL
24	Diaphragm	NBR REINFORCED
25	Piston	C.STEEL
26	Piston Nut	S.S.
27	Actuator Spring	SPRING STEEL
28	Actuator Upper Case	C.STEEL
33	Positioner Bracket	S.S.
35	Limit Switch Bracket	S.S.
36	Pin	S.S.
46	Positioner	-
47	Filter Regulator	-

Note :Materials of construction may change depending on application

